

# Load restraint assemblies on road vehicles — Safety —

## Part 2: Web lashing made from man-made fibres

The European Standard EN 12195-2:2000 has the status of a  
British Standard

ICS 53.080; 55.180.99

## National foreword

This British Standard is the English language version of EN 12195-2:2000. It supersedes BS 5759:1987, which was withdrawn on 15 December 2001.

The UK participation in its preparation was entrusted to Technical Committee MHE/16, Load restraint assemblies, which has the responsibility to:

- aid enquirers to understand the text;
- present to the responsible international/European committee any enquiries on the interpretation, or proposals for change, and keep UK interests informed;
- monitor related international and European developments and promulgate them in the UK.

A list of organizations represented on this committee can be obtained on request to its secretary.

### Cross-references

The British Standards which implement international or European publications referred to in this document may be found in the *BSI Catalogue* under the section entitled “International Standards Correspondence Index”, or by using the “Search” facility of the *BSI Electronic Catalogue* or of British Standards Online.

This publication does not purport to include all the necessary provisions of a contract. Users are responsible for its correct application.

**Compliance with a British Standard does not of itself confer immunity from legal obligations.**

### Summary of pages

This document comprises a front cover, an inside front cover, the EN title page, pages 2 to 24, an inside back cover and a back cover.

The BSI copyright notice displayed in this document indicates when the document was last issued.

### Amendments issued since publication

| Amd. No.                   | Date       | Comments                         |
|----------------------------|------------|----------------------------------|
| 15863<br>Corrigendum No. 1 | March 2006 | Addition of supersession details |
|                            |            |                                  |
|                            |            |                                  |
|                            |            |                                  |

This British Standard, having been prepared under the direction of the Engineering Sector Committee, was published under the authority of the Standards Committee and comes into effect on 15 January 2001

© BSI 7 March 2006

ICS 53.080; 55.180.00

English version

## Load restraint assemblies on road vehicles - Safety - Part 2: Web lashing made from man-made fibres

Dispositifs d'arrimage des charges sur véhicules routiers -  
Sécurité - Partie 2: Sangles en fibres synthétiques

Ladungssicherungseinrichtungen auf Straßenfahrzeugen -  
Sicherheit - Teil 2: Zurrgurte aus Chemiefasern

This European Standard was approved by CEN on 26 June 2000.

CEN members are bound to comply with the CEN/CENELEC Internal Regulations which stipulate the conditions for giving this European Standard the status of a national standard without any alteration. Up-to-date lists and bibliographical references concerning such national standards may be obtained on application to the Management Centre or to any CEN member.

This European Standard exists in three official versions (English, French, German). A version in any other language made by translation under the responsibility of a CEN member into its own language and notified to the Management Centre has the same status as the official versions.

CEN members are the national standards bodies of Austria, Belgium, Czech Republic, Denmark, Finland, France, Germany, Greece, Iceland, Ireland, Italy, Luxembourg, Netherlands, Norway, Portugal, Spain, Sweden, Switzerland and United Kingdom.



EUROPEAN COMMITTEE FOR STANDARDIZATION  
COMITÉ EUROPÉEN DE NORMALISATION  
EUROPÄISCHES KOMITEE FÜR NORMUNG

Management Centre: rue de Stassart, 36 B-1050 Brussels

---

| <b>Contents</b>  | <b>Page</b> |
|--|-------------|
| <b>Foreword</b> .....  | <b>3</b>    |
| <b>Introduction</b> .....  | <b>4</b>    |
| <b>1 Scope</b> .....   | <b>4</b>    |
| <b>2 Normative references</b> .....  | <b>4</b>    |
| <b>3 Terms and definitions</b> .....   | <b>5</b>    |
| <b>4 Hazards</b> .....   | <b>9</b>    |
| <b>5 Safety requirements</b> .....   | <b>10</b>   |
| <b>6 Verification of safety requirements and type tests</b> .....  | <b>13</b>   |
| <b>7 Test report</b> .....   | <b>19</b>   |
| <b>8 Marking</b> .....   | <b>19</b>   |
| <b>9 Instructions for use</b> .....  | <b>20</b>   |
| <b>Annex A (normative) Hazards</b> .....   | <b>21</b>   |
| <b>Annex B (normative) Specification for information for use and maintenance of web lashing to be provided by the manufacturer</b> ..... | <b>23</b>   |

## Foreword

This European Standard has been prepared by Technical Committee CEN/TC 168 "Chains, ropes, webbing, slings and accessories – Safety", the secretariat of which is held by BSI.

This European Standard shall be given the status of a national standard, either by publication of an identical text or by endorsement, at the latest by May 2001, and conflicting national standards shall be withdrawn at the latest by May 2001.

This European Standard has been prepared under a mandate given by CEN by the European Commission and the European Free Trade Association.

The annexes A and B are normative.

This series EN 12195 "Load restraint assemblies on road vehicles — Safety" consists of the following parts:

Part 1: Calculation of lashing forces

Part 2: Web lashing made from man-made fibres

Part 3: Lashing chains

Part 4: Lashing wire ropes

According to the CEN/CENELEC Internal Regulations, the national standards organizations of the following countries are bound to implement this European Standard: Austria, Belgium, Czech Republic, Denmark, Finland, France, Germany, Greece, Iceland, Ireland, Italy, Luxembourg, Netherlands, Norway, Portugal, Spain, Sweden, Switzerland and the United Kingdom.

## Introduction

This European Standard has been prepared to be a harmonized standard to provide conformity of the safety requirements for web lashings on the European Market and thus to enable free trade.

The extent to which hazards are covered is indicated in the Scope of the Standard. In addition web lashings for securing of loads on vehicles shall conform as appropriate to EN 292 for hazards which are not covered by this Standard.

## 1 Scope

This Part of EN 12195

- specifies safety requirements for web lashing made from man-made fibres with flat woven webbings for multiple use and of lashing combinations with woven webbings for the safe surface transport of goods on road vehicles, e.g. trucks and trailers which are used on roads or located on vessels or on rail waggons and/or combinations thereof;
- includes only tensioning devices to be hand driven with a maximum hand force of 500 N;
- specifies methods for testing of web lashing for securing of loads;
- deals with the significant hazards which could occur when web lashings are in use as intended and under conditions foreseen by the manufacturer (see clause 4 and Annex A);
- includes composite load restraint assemblies also for the same purpose as above.

## 2 Normative references

This European Standard incorporates by dated or undated reference, provisions from other publications. These normative references are cited at the appropriate places in the text and the publications are listed hereafter. For dated references, subsequent amendments to or revisions of any of these publications apply to this European Standard only when incorporated in it by amendment or revision. For undated references the latest edition of the publication referred to applies (including amendments).

EN 292-1:1991, *Safety of machinery — Basic concepts, general principles for design — Part 1: Basic terminology, methodology.*

EN 292-2:1991, *Safety of machinery — Basic concepts, general principles for design — Part 2: Technical principles and specifications.*

prEN 12195-1:1995, *Load restraint assemblies on road vehicles — Safety — Part 1: Calculation of lashing forces.*

EN ISO 9001:1994, *Quality systems — Model for quality assurance in design, development, production, installation and servicing (ISO 9001:1994).*

EN ISO 9002:1994, *Quality systems — Model for quality assurance in production, installation and servicing (ISO 9002:1994).*

EN ISO 9003:1994, *Quality systems — Model for quality assurance in final inspection and test (ISO 9003:1994).*

EN 10002-2:1991, *Metallic materials — Tensile testing — Part 2: Verification of the force measuring system of the tensile testing machines.*

ISO 1833:1977, *Textiles — Binary fibre mixtures — Quantitative chemical analysis.*

ISO 2076:1999, *Textiles — Man-made fibres — Generic names.*

ISO 2859-1:1989, *Sampling procedures for inspection by attributes — Part 1: Sampling plans indexed by acceptable quality level (AQL) for lot-by-lot inspection.*

ISO 9227:1990, *Corrosion tests in artificial atmospheres — Salt spray tests.*

### 3 Terms and definitions

For the purposes of this European Standard, the following terms and definitions apply.

systems and devices for the securing of loads

device designed to be attached to the lashing points in order to secure the cargo on a road vehicle; the lashing equipment consists of tensioning elements (e. g. webbing, chain, wire rope), tensioning devices (e. g. wrench, ratchet, spanner, tension jack) and connecting components, if required (e. g. hook, terminal link)

means of securing as under 3.2, consisting of a tensioning device or a tension retaining device and flat woven textile webbing with or without end fittings (see figure 1c: two-piece web lashing)

conventional or shuttleless woven narrow fabric, generally with multiple plies, and the prime function of which is loadbearing; a characteristic of webbing is its narrow fabric selvages

mechanical device inducing and maintaining a tensile force in a load restraint assembly (e. g. ratchets, winches, overcentre buckles; see figure 2, C1 to C5)

device connecting the means of web lashing or the tensioning device with the lashing point of the vehicle or the attachment point of the load (see figure 2, D1 to D7)

device which indicates the force applied to the lashing system by means of the tension devices and movement of the load or elastic deformation of the vehicle body, acting on the lashing equipment

web lashing which comprises only one flat woven textile webbing and a tensioning device with end fittings (see figure 1b), shown with floating end fittings

web lashing which comprises two woven textile webbings, one with a tensioning device, both with one end fitting (see figure 1c)

the length of a one-piece web lashing measured from the free end of the webbing to the outer turning radius of its connection to the tensioning device



a) Single part web lashing



b) Single part web lashing in endless configuration with floating end fittings



c) Two-piece web lashing



d) Force improving web lashing

**Figure 1 — Examples of web lashings**



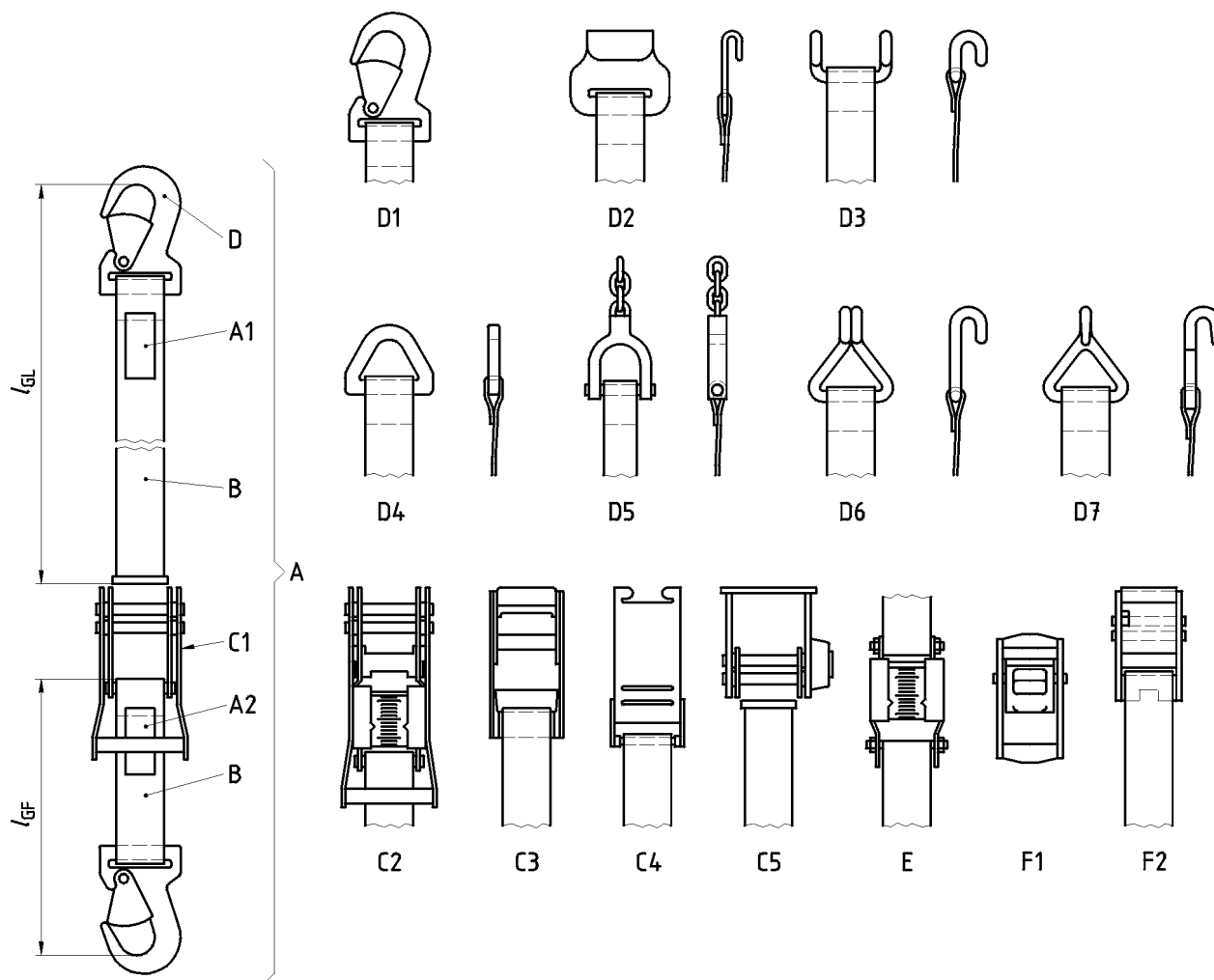

### Key

- A complete lashing equipment: web lashing
- A1, A2 marking (label)
- B tensioning element: flat woven textile webbing
- C tensioning devices
- C1 ratchet tensioner
- C2 ratchet tensioner with tension force indicator (see also E)
- C3, C4 overcentre buckle
- C5 lashing winch
- D end fittings
- D1 snap hook, flat, swivel or twisted
- D2 flat hook
- D3 chassis hook
- D4 triangle, designed to engage with an anchorage
- D5 connector to chain
- D6 wire claw hook, double
- D7 wire claw hook, single
- E tension force indicator (see also C2)
- F1 tension retaining device (cambuckle)
- F2 sliding bar buckle

**Figure 2 — Examples of web lashings, including tensioning device C, end fitting D, tension force indicator E and tension retaining device F**

the length of a fixed end, measured from the force bearing point of the end fitting to the outer turning radius of the connection of the webbing to the tensioning device (see figure 2 and 3)

the length of an adjustable end, measured from the free end of the webbing to the force bearing point of the end fitting (see figure 2 and 3)

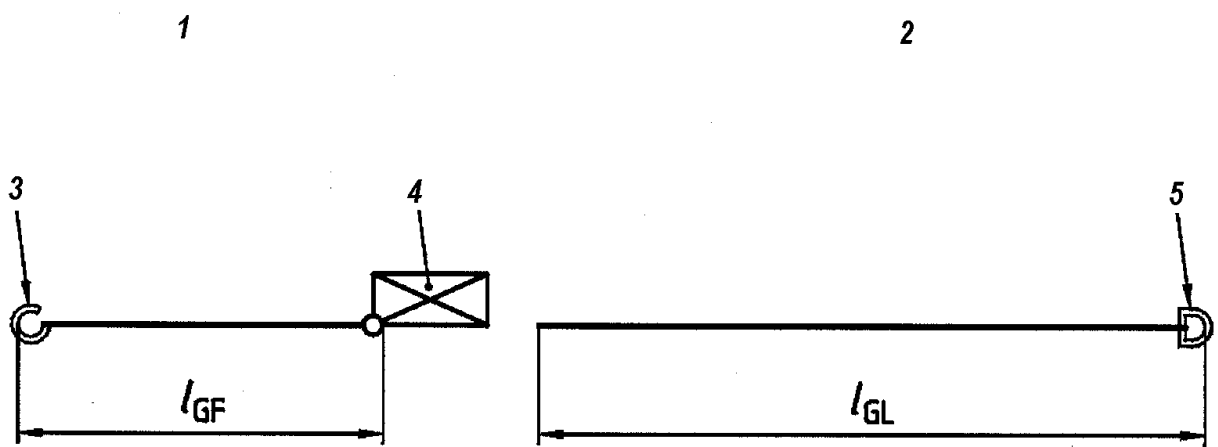

**Key**

- 1 Fixed end
- 2 Adjustable end
- 3 End fitting
- 4 Tensioning device or tension retaining device
- 5 End fitting

**Figure 3 — Two-piece web lashing**

device for securing a load, consisting of a tensioning device and a textile webbing combined with chains or steel wire ropes with or without end fittings

securing device on a vehicle to which a lashing may be directly attached; a lashing point can be e. g. an oval link, a hook, a ring, a lashing shoulder

maximum force that the web lashing withstands when tested, i. e. complete with ratchet and end fittings

breaking force for which the web lashing is designed

ratio of the minimum breaking force  $BF_{min}$  to the lashing capacity LC

maximum force for use in straight pull that a web lashing is designed to sustain in use

force applied to the handle which creates the tensile force in the web lashing

hand operating force of 500 N (50 daN on the label)

residual force after release of the handle of the ratchet

a designated person, suitably trained qualified by knowledge and practical experience and with the necessary instructions to enable the required tests and examinations to be carried out

NOTE Subclause 4.18 of EN ISO 9002:1994 gives guidance on training.

a series of letters and/or numbers marked on a component which enables its manufacturing history, including identity of the webbing, to be traced

## 4 Hazards

The general hazards caused by the load or parts of load during improper use of web lashings or the non-use of any load securing devices are given in Annex A.

Hazards described in the following refer to persons who can be endangered directly when handling the web lashings, i. e. during tensioning and unloading.

The evaluation of hazards is carried out according to EN 292-1.

Clause 1 "Scope", 2nd sentence, permits this "for other technical products having similar hazards". This is applicable, since mistakes lead to substantial general hazards (see Annex A) and because the tension in the webbing used with hand-operated web lashings leads to similar or more severe hazards as with mechanically operated lashing winches.

The requirements of clause 5, the tests in clause 6, and the user's instructions have been harmonized such that during proper use of webbings and tensioning devices conforming to this standard these are designed and dimensioned such that the following hazards are taken into account, if they are used in accordance with the manufacturers instructions:

- a) Hazards of being hit by tilting or shifting loads, losing balance or falling during application and tensioning of the lashings due to defective equipment, sudden breakage or malfunction of the tensioning device leading to the sudden absence of the hand reaction force.
- b) Injuries by pinching and shearing, hand and arm injuries during manipulation of tensioning devices due to sharp edges.
- c) Hazards to the unloading personnel due to loads having moved or being tilted during transport because of inadequate securing, malfunction like recoil or breakage of equipment or defective equipment and then which may fall onto the personnel, especially when opening the side-panels.
- d) Hazards due to wrong combinations made up by the operator (combination of lashings or components with different LC).

- e) Hazards to the unloading personnel by using tensioning devices in web lashings which do not permit their controlled release so allowing an unstable load to move suddenly.
- f) Hazards to operators from excessive recoil of levers and cranks of the tensioning devices.

The ergonomic requirements are taken into account by the fact that the maximum hand force has been defined in 3.18 and 6.5.1. Some persons, however, are able to apply with 2 hands or unpermitted levers considerably higher forces. Accordingly reference is made in the user's instructions on the hand force having a value of  $\leq 500$  N.

Table A.1 in Annex A gives a survey of all hazards and the corresponding requirements.

## **5 Safety requirements**

### **5.1 General**

All load bearing parts of the complete web lashing shall show no evidence of deformation or other defects that affect the function at 1,25 LC.

- a) The tensioning device or components with moving parts shall fully retain its function: any permanent set in the longitudinal axis of the webbing slot shall be less than 2 % of the width of webbing;
- b) No seam failure shall occur;
- c) No slippage of the textile webbing through the tensioning device shall occur after settling.

Afterwards it shall withstand a force of at least a coefficient of utilisation of 2 when all parts are tested in accordance with 6.4.

### **5.2 Flat woven textile webbing**

When loaded to LC the flat woven textile webbing shall not elongate by more than 7 % when tested according to 6.3. A new unsewn textile webbing to be used in web lashings shall sustain a tension force of at least 3 LC when tested according to 6.3.

### **5.3 Tensioning devices**

#### **5.3.1 General**

There shall be no sharp edges or burrs which may come into contact with textile webbings or the operator's hands. If removable hand cranks are used they shall be secured against accidental detachment.

The backlash of the lever end of the tensioning device (in case of winches, the crank) under a tensile force shall not exceed 150 mm when opened.

Tensioning devices shall be designed to exclude an unintentional release of the tension in the lashing.

With a force corresponding to 0,3 LC applied to the web lashing, it shall be possible to disengage the tensioning device without tools so that it shall be re-usable after the test according to 6.5.2.

Tensioning devices based upon winch principles shall be designed in such a way that after 2 1/4 turns around the slotted pin, the loose end does not slide out (see Table 1).

Tensioning devices shall be in such a way that, when used as intended by the manufacturer, there are no crushing or shearing points which might lead to the operator's hands being injured.

There is no specific requirement for corrosion resistance, however, if such a requirement forms part of a contract, the test method used shall be the Natural Salt Spray Test (NSS) as specified in ISO 9227.

NOTE The duration of the test should be agreed on between the interested parties.

### 5.3.2 Hand-operated tensioning device

#### 5.3.2.1 General

A remaining tension of at least 0,1 LC and not more than 0,5 LC shall be generated in the web lashing after the standard hand force of 500 N has been applied to the handle of the tensioning device. The requirement of a remaining tension of at least 0,1 LC applies only for hand-operated tensioning devices, which are designed for frictional lashing to be used in web lashings with labelled  $S_{TF}$ .

The seating of a tensioning device in contact with the webbing shall be well rounded, so that when tested in accordance with clause 6:

- there is no damage likely to affect safety to the area of textile webbing in contact with the tensioning device;
- the tensioning device shows no sign of permanent deformation, cracks, flaws or other defects likely to affect safety when examined by a competent person.

If removable handcranks are used they shall be secured against unintended detachment when loaded.



The tensioning device (ratchets) shall require positive action to release the tension in the web lashing. The tensioning device shall take a minimum of 2 ¼ turns of textile webbing around the slotted pin.

#### 5.3.2.2 Cyclic loading test of tensioning devices and tension retaining devices

Tests on cyclic loading shall be carried out on web lashings of  $LC \geq 5$  kN.

The web lashing shall resist 100 alternations at a frequency not higher than 0,4 Hz between 0,2 LC and 1,0 LC without settling more than is given in Table 1 (see also 6.6).

**Table 1 — Allowed settling of the textile webbing after cyclic loading test**

| Lashing capacity LC<br>kN   |   | Allowed settling with 2 ¼ turns around<br>the rotating axis<br>mm |
|---|---|---|
|  |  |   |
| 5 < LC ≤ 20   | 10 < LC ≤ 40  | 15  |
| 20 < LC ≤ 40  | 40 < LC ≤ 80  | 20  |
| 40 < LC   | 80 < LC   | 25  |

#### 5.3.2.3 Ratchet strength

The ratchet has to withstand a force as given in Table 2, applied on the handle without failure when tested in accordance with 6.5.4. The force is applied on the central 1/3 of the handle width or by a textile webbing equal to the one used.

**Table 2 — Minimum breaking force of ratchet at strength test using the ratchet handle**

| Internal width of ratchet<br>mm | Handle test force<br>N |
|---------------------------------|------------------------|
| 25                              | 500                    |
| 35                              | 1500                   |
| 50                              | 2500                   |
| 75                              | 3500                   |
| 100                             | 3500                   |

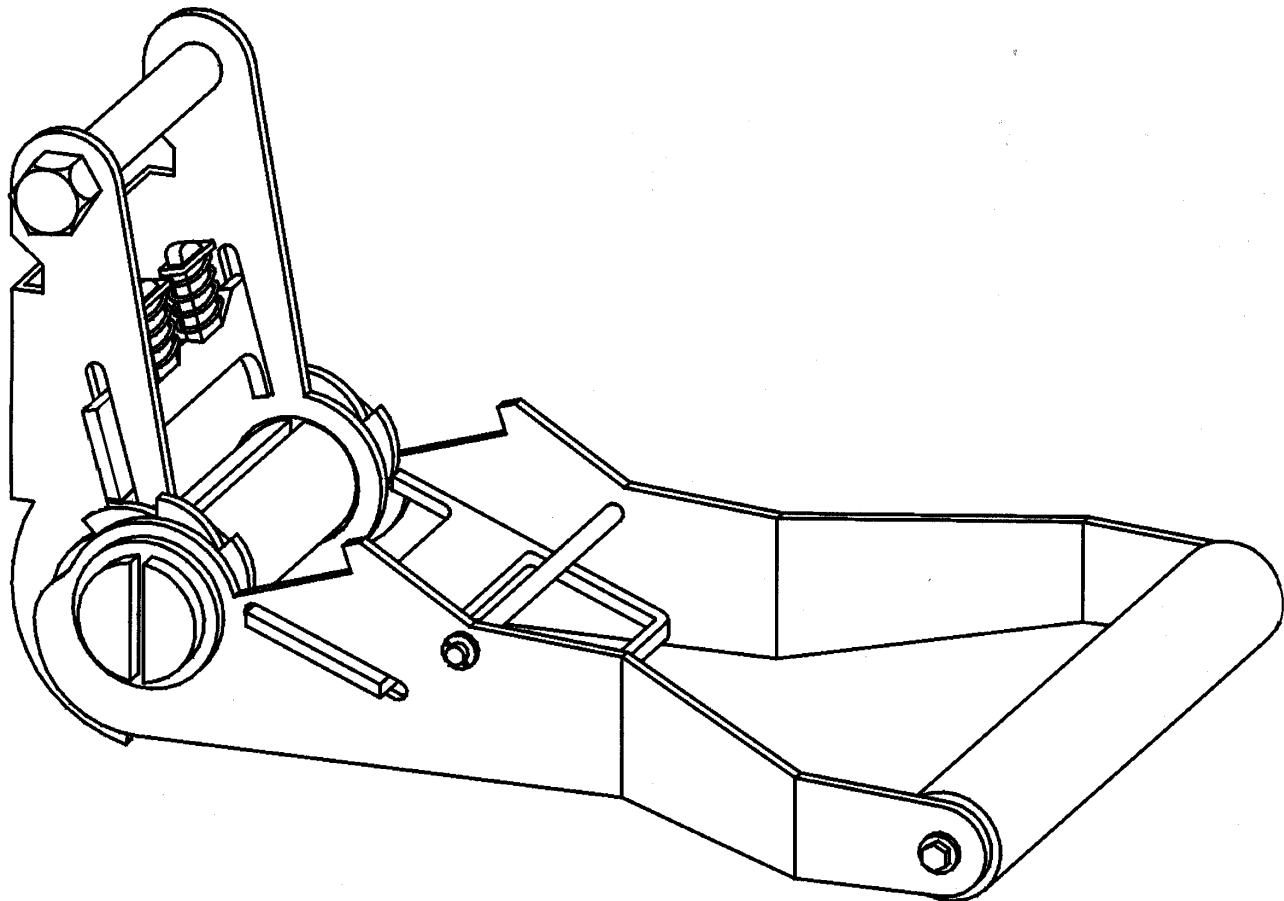

**Figure 4 — Crossbar type ratchet**

#### **5.3.2.4 Winch cranks**

On web lashings containing a winch, the crank or handle of which is demountable, the design of the winch shall be to ensure that inadvertent detachment or release of the crank or handle is prevented.

#### **5.4 End fitting**

End fittings shall not present any sharp corners, edges and burrs and shall be so designed that no crushing and shearing points arise.

There is no specific requirement for corrosion resistance, however, if such a requirement forms part of a contract, the test method used shall be the NSS-test as specified in ISO 9227.

NOTE The duration of the test should be agreed on between the interested parties.

## 5.5 Tension retaining device

Tension retaining devices shall fulfill the same requirements as given for end fittings in 5.4, sentence 1 and 2. They shall not allow any slippage of the webbing after closure is complete when tested in accordance with 6.6.

## 5.6 Performance characteristics of the textile webbing

The textile webbing shall be produced wholly from high tenacity yarns fast to light and heat stabilised with a tenacity of not less than 60 cN per tex from one of the following materials:

Polyamide (PA), high tenacity continuous multifilament;

Polyester (PES), high tenacity continuous multifilament;

Polypropylene (PP), high tenacity continuous multifilament.

NOTE 1 The definitions for these are given in ISO 2076. The content of the constituent materials may be determined in accordance with ISO 1833.

NOTE 2 Attention is drawn to the different resistance of man-made fibres to chemicals as summarized in Annex B.9.

All seams shall be made from thread of the same material as that of the webbing and shall be made with a locking stitch.

NOTE 3 To facilitate inspection, the sewing thread may be of a different colour from that of the webbing.

## 5.7 Tension force indicator (optional)

Where a tension force indicator is fitted, the indicated values shall be easily readable.

For mechanical systems the minimum movement of the indicators shall be  $(10 \pm 1,5 \text{ mm})/10 \text{ kN}$  within a temperature range of  $-10 \text{ }^\circ\text{C}$  to  $+40 \text{ }^\circ\text{C}$ .

The same requirements as specified for tensioning devices shall apply by analogy to tension force indicators. If the tension force indicator fails the design shall ensure that the web lashing becomes not disconnected.

# 6 Verification of safety requirements and type tests

## 6.1 General

Type tests in accordance with 6.3 to 6.7 shall be carried out on at least two samples of each type.

Production tests in accordance with 6.3 and 6.4 shall be carried out on samples taken in accordance with 6.2.



## 6.2 Sampling for production tests

Two samples of web lashings which may vary only in the webbing length and which are considered to be uniform shall be taken at random from series production or manufactured lots. The sampling shall be carried out in accordance with ISO 2859-1:1989, clause 8, and shall correspond with the reduced test requirements.

For manufacturers who do not have an approved and operating QA system in accordance with EN ISO 9001, EN ISO 9002 or EN ISO 9003, the sampling rates shall be as given in Table 3.

For manufacturers who have an approved and operating QA system in accordance with EN ISO 9001, EN ISO 9002 or EN ISO 9003, the sampling rates may be reduced, provided that the requirements for change of procedure in accordance with ISO 2859-1 are complied with. In such cases the lot sizes listed in Table 3 may be doubled.

**Table 3 — Sampling rate for tensile testing of complete web lashings**

| Lashing capacity LC kN<br> | Lashing capacity LC kN<br> | Lot size<br>Minimum sampling rate<br>2 samples per every |
|---|---|--|
| up to 5   | up to 10  | 6000 pieces  |
| over 5 up to 10   | over 10 up to 20  | 3000 pieces  |
| over 10 up to 30  | over 20 up to 60  | 2000 pieces  |
| over 30   | over 60   | 1000 pieces  |

NOTE Table 3 corresponds to table II-c "simple reduced" of ISO 2859-1:1989 "Acceptance sampling test" with the sampling size C.

### 6.3 Tensile test of textile webbings

Cut off a sample of the textile webbing from the webbing batch used in the manufacture of the web lashing, or the webbing at the unsewn end of the web lashing to be tested, to the required testing length. Assemble the sample into the test machine so that it is straight and without twist.

Load the textile webbing to 0,05 LC. Mark a gauge length between 0,1 m min. and 1,0 m max. in the centre of the webbing sample width. Accuracy of length measurement shall be  $\pm 0,5\%$ .

Increase the load to the force equivalent of LC. Measure the distance between the gauge marks and determine the elongation (max. 7 %).

Apply the minimum breaking force of 3 LC so that the elongation of the textile webbing takes place at a continuous rate between 50 mm/min and 110 mm/min per 1000 mm length of the specimen.

### 6.4 Testing of the complete web lashing

The samples taken shall be submitted to a visual inspection, ensuring that no sharp edges and burrs come into contact with the webbings or the operator's hands and that no hand injuries by crushing and shearing may occur.

Assemble the complete web lashing with its end fittings using ordinary means of attachment for mounting in a tensile testing machine. If the tensioning element in the web lashing is a ratchet the slotted axis shall be in position 5b, (see Figure 5). The machine shall be calibrated and certified in accordance with EN 10002-2 and shall conform to class 1 conditions of accuracy. It shall be equipped with appropriate attachment points.

Load the web lashing to 1,25 LC, maintained for one minute. The test shall be carried out with  $2\frac{1}{4}$  turns around the rotating axis.

All load bearing parts of the complete web lashing shall show no evidence of deformation or any other defect that affect the function.



After release of this force

- inspect the components for permanent distortion;
- no malfunction shall occur, as described in 5.1 a, b and c.

NOTE Elongation of the material of the webbing and circumferential bedding in of the tensioning device should not be confused with slippage of the webbing in the tensioning device.

After this inspection the complete web lashing shall withstand at least 2 LC without failure (with 2  $\frac{1}{4}$  turns around the rotating axis also).

NOTE The breaking force may then be determined.

Other end fittings or means of attachment shall be tested. This may be done with the webbing only (without ratchet) so that all combinations may then be considered tested.

## 6.5 Type testing for ratchets and other tensioning devices with rotating axis

### 6.5.1 Test of pre-tension ability

The complete web lashing shall be attached to two fixed points 0,5 m to 4 m apart, or a corresponding vertical or horizontal testing machine shall be utilised. Usually the upper clamping device is connected with the force measuring device.

When a web lashing with ratchet is to be tested, the slotted axis into which the webbing has been inserted shall be turned 1  $\frac{1}{4}$  times at the beginning of the test including the long loose end (see Figure 5b). The textile webbing shall be positioned such that after 1  $\frac{1}{4}$  turns tension is built up in the web lashing. The maximum value is 0,05 LC (see Figure 5).

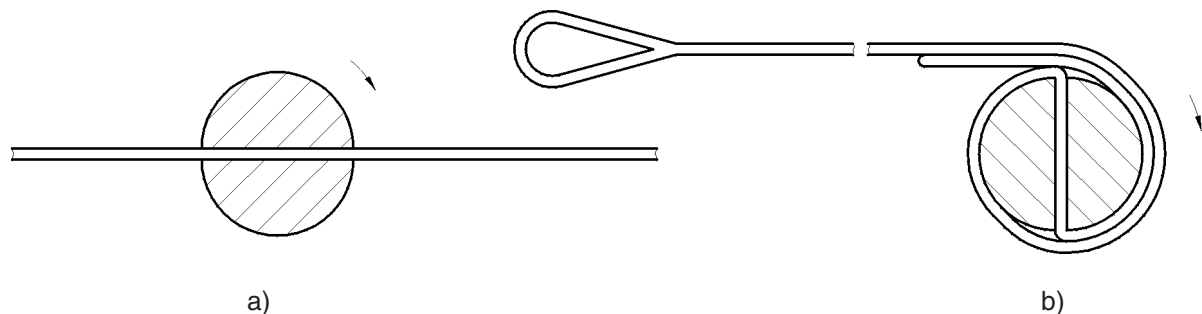
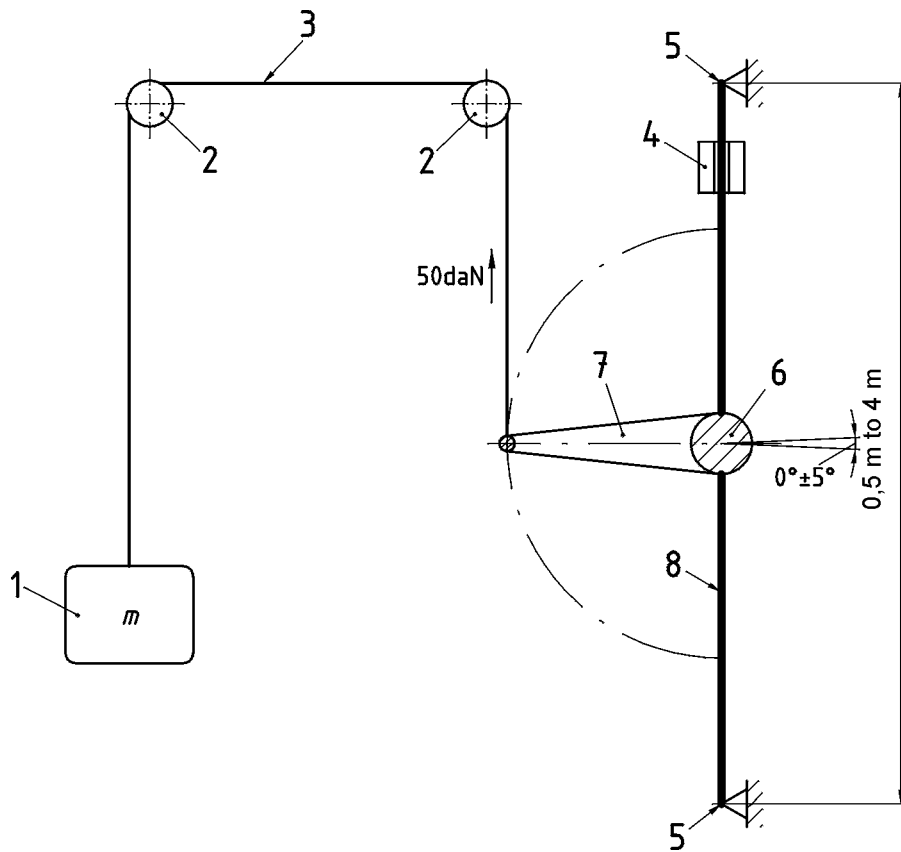

Figure 5 — Testing procedure

The handle shall then be moved so that, when applying the standard hand force, it is situated at right angles ( $\pm 5^\circ$ ) to the axis of the textile webbing (see Figure 6). The handle shall then be released in order to activate the locking device. Measure the force that the tensioning device retains in the web lashing 10 seconds after the handle has been released. Repeat this procedure 4 times (in case of uneven number of teeth  $2 \times 3$  times,  $180^\circ$  different starting position) after re-positioning the textile webbing in the slot and calculate the mean value of 4 (in case of uneven number of teeth delete the maximum and minimum value); it shall have a max. value of 0,5 LC and for ratchets and other tensioning devices with rotating axis designed for frictional lashing a min. value of 0,1 LC or more in steps of 0,02 LC (e. g. 0,12 LC; 0,14 LC; 0,16 LC; 0,18 LC; 0,20 LC...).



### Key

- 1 Load
- 2 Idler pulleys
- 3 Rope
- 4 Force transducer
- 5 Fixing point
- 6 Slotted axis
- 7 Handle
- 8 Textile webbing

**Figure 6 — Schematic arrangement for testing the pre-tensioning ability of ratchets**

### 6.5.2 Test of the ability to release under tension

The ability to release under tension shall be tested by loading the web lashing to 0,3 LC, and releasing the tension in the web lashing by hand without the use of tools.

After release of the load, the following characteristics of the tensioning device shall be noted:

- ability to release by hand without tools;
- appraisal of any hazard to the operator at release.

### 6.5.3 Cyclic loading test

#### 6.5.3.1 For ratchets and winches

The textile webbing shall be wound  $2\frac{1}{4}$  times around the split pin at the start of the test. The length of the free textile webbing shall be (0,5 - 1,0) m (see Figure 7).

Load the web lashing in straight pull with a force equivalent to LC.

Reduce the load to 0,2 LC.

Draw a line, e. g. with a marker pen, on the textile webbing at the tensioning device.

Subject the web lashing to 100 cycles at a frequency not exceeding 0,4 Hz between 0,2 LC and 1,0 LC.

Measure the circumferential settling of the textile webbing at 0,2 LC; the values of Table 1 shall not be exceeded.

NOTE 1 The sample used for the cyclic loading test may be used for the determination of the breaking force.

NOTE 2 Two possible fixings in the test machine for the cyclic loading test procedure are shown in figure 7.

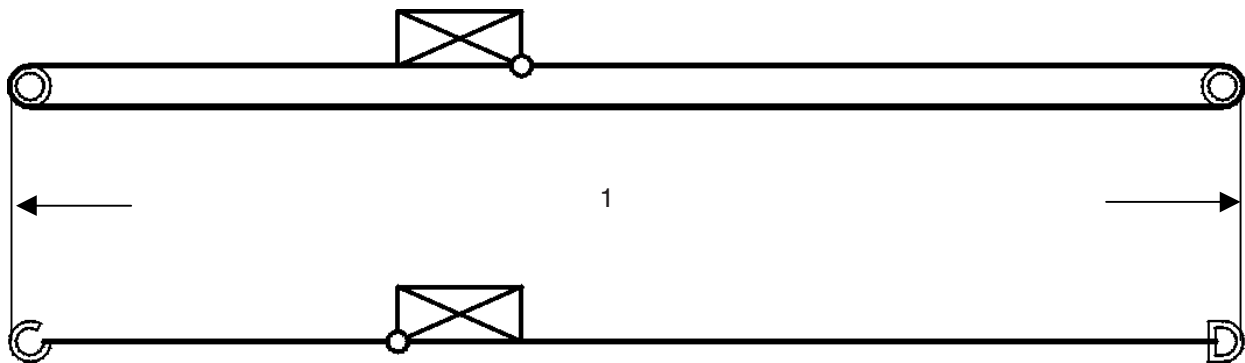

#### Key

1 length of the free textile webbing

Figure 7 — Fixings for cyclic loading test

#### 6.5.3.2 For other tensioning devices and tension retaining devices

Insert the web lashing into the device (if appropriate, as shown in Figure 6).

Secure the device, and load to 1 LC.

Reduce the load to 0,2 LC.

Draw a line, e. g. with a marker pen, on the web lashing at the device.

Subject the web lashing to 100 cycles between 0,2 LC and 1,0 LC at a frequency not exceeding 0,4 Hz.

On completion of the test, the position of the line relative to its initial position shall be checked at 0,2 LC. The movement of the line shall not exceed the limits stated in Table 1.

### 6.5.4 Strength test using the ratchet handle

Mount the sample handle into a fixture such that the slotted axis is prevented from turning (see Figure 8). Apply a force acting at  $90^\circ$  to the handle. Increase the force until failure occurs. Note the breaking force and the location of the rupture.

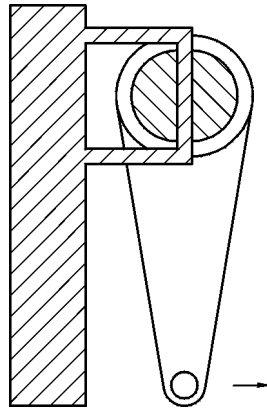

**Figure 8 — Positioning for strength test of the handle**

### **6.5.5 Testing of winch cranks**

On web lashings containing a winch, the crank or handle of which is demountable, the design of the winch shall be investigated visually and a function test shall be made by hand to make sure that inadvertent detachment or release of the crank or handle is prevented.

### **6.6 Type testing for other tensioning devices and tension retaining devices**

The type tests for these devices shall consist of:

- the cyclic loading test (6.5.3.2);
- the test of the ability to release under tension (6.5.2);
- the test of recoil (6.7).

### **6.7 Test of recoil**

When moving the lever of tensioning devices during the test in accordance with 6.5.2, the recoil at the end of the handle buckle or lever shall be measured (max. 150 mm).

### **6.8 Re-tests and acceptance criteria**

When type testing, if either of the two samples fails to meet the requirements of one or more of the tests in 6.3 or 6.7, two more similar samples shall be tested.

When production testing, if one sample fails to meet the requirements of one or more of the tests in 6.2 or 6.4, two more samples shall be taken from the same production series or batch and shall be tested.

If any sample for re-testing, for either type or production testing, fails to meet the requirements of any of the above tests, the web lashing shall be considered as not meeting the requirements of this Part of EN 12195.

## 7 Test report

The following points shall be reported to be part of the technical file of the manufacturer:

- if the web lashing fails during the test (6.3 and 6.4);
- any damage to the webbing surface;
- any signs of permanent distortion, cracks, flaws or other defects on the fittings or tensioning device (6.4);
- maximum tensile force applied (6.4);
- that at 2 LC no failure occurred (6.4);
- mean value of the pre-tension force and obtained level (6.5.1);
- results of the cyclic loading test (6.5.3/6.6);
- result of the handle strength test (6.5.4);
- result of re-tests (6.8).

## 8 Marking

The marking shall be according to EN 292-2:1991, clause 5.4. Each complete web lashing, if it is intended that parts be separable, shall be marked with the following information if applicable on a label (see Figure 9):

- lashing capacity LC;
- lengths  $L_G$ ,  $L_{GF}$  and  $L_{GL}$  in metre;
- standard hand force  $S_{HF}$ ;
- standard tension force  $S_{TF}$  (daN) or winch force, based on the level for which the tensioning device has been type tested, when designed for frictional lashing;
- warning: "Not for lifting!";
- material of the textile webbing;
- manufacturer's or supplier's name or symbol;
- manufacturer's traceability code;
- number and part of this European Standard, i. e. EN 12195-2;
- year of manufacture;
- elongation of textile webbing in % at LC.

End fittings, tensioning devices, tension retaining devices and tension indicators of  $LC \geq 5$  kN shall be marked with the manufacturer's or supplier's name or symbol.

The value of LC shall be marked on parts with  $LC \geq 5$  kN in kN, on parts with  $LC < 5$  kN in daN.

Labels shall have the following colours:

- |         |             |
|---------|-------------|
| - blue  | PES webbing |
| - green | PA webbing  |
| - brown | PP webbing  |

|   |                                     |           |  |
|---|-------------------------------------|-----------|--|
| Lashing capacity  | LC ..... daN                        | SECTION B |  |
| Standard tension force  | $S_{HF}$ 50 daN/ $S_{TF}$ ..... daN |           |  |
| Webbing material  |                                     |           |  |
| Length ( $L_G$ , $L_{GF}$ or $L_{GL}$ , as applicable)  | $L$ .....                           |           |  |
|   | <b>"Not for lifting!"</b>           |           |  |
| Name of manufacturer or supplier, their symbol, registered trade mark or other unambiguous identification |                                     |           |  |
| Manufacturer's traceability code  |                                     |           |  |
| Year of manufacture   |                                     |           |  |
| Standard number   | EN 12195-2                          |           |  |
| Lashing capacity  | LC ..... daN                        |           |  |
| Webbing material  |                                     |           |  |
| Supplier  |                                     |           |  |
| Manufacturer's traceability code  |                                     |           |  |
| Year of manufacture   |                                     |           |  |
| Standard number   | EN 12195-2                          |           |  |

Figure 9 — Typical label format

## 9 Instructions for use

Instructions for use shall accompany each web lashing or web lashing equipment in accordance with Annex B.

## **Annex A** **(normative)**

### **Hazards**

#### **A.1 General**

The release of load or parts of load caused by improper securing puts at risk either directly or indirectly the life or health of persons, pets or goods within the danger zone of the vehicle. The description of the danger zone of the moving vehicle is covered by A.2, A.5 and A.7. The danger zones of the standing vehicle are defined in 4 a, b and c.

**A.2** General traffic hazards on private and public roads by release or displacement of load; hazards by load coming into contact with buildings, other vehicles, structures (tunnels, bridges).

**A.3** Overturning of the vehicle on curves, evasive action; displaced load causing uneven weight distribution resulting in mishap.

**A.4** Hazards on ships by release of load, hazards by vehicles standing side by side, hazards to the life and health.

**A.5** Hazards on trains by release of load, hazards to oncoming trains, safety of rail traffic, stations and people; hazards by load coming into contact with buildings, other vehicles, structures (tunnels, bridges).

**A.6** Hazards to the driver and the assistant driver and all other road users.

**A.7** Hazards by load sliding forward or tilting during braking, destroying and damaging the cabin.

**A.8** Hazards by contact of overhead power lines with personnel, load or lashing equipment.

**Table A.1 — Hazards and associated requirements**

| Hazards identified in EN 292-1<br>Paragraph | Hazards identified in EN 292-1<br>Description    | Relevant clause/sub-clause of this<br>European Standard |
|---|--|---|
| 3.10  | Danger zone                                      | Annex B   |
| 3.12  | Information to user                              | 7, 8 and Annex B  |
| 3.12  | Intended use                                     | 8, Annex B  |
| 3.12  | Foreseeable misuse                               | 8, No. 5  |
| 3.18  | Risk reduction by design                         | 5 and 6   |
| 3.20  | Information for use Texts                        | 7, 8 and Annex B  |
| 4.2.1                                       | Description of hazards<br>Mechanical             | 4   |
| 4.2.2                                       | Description of hazards<br>Mechanical             | 4 and 5 and Annex A                                     |
| 4.8   | Hazards generated by materials<br>and substances | Annex B   |
| 5.1   | Limits of use                                    | 8 and Annex B   |
| 5.2   | Systematic assessment                            | Annex B   |
| 5.3   | Removal of hazards                               | 7   |
| 5.4   | Safeguarding against hazards                     | 7   |
| 5.5   | Informing and warning                            | 7 and 8   |

**Table A.2 — Hazards and associated requirements**

| Hazards identified in EN 292-2<br>Paragraph | Hazards identified in EN 292-2<br>Description | Relevant clause/sub-clause of this<br>European Standard |
|---|---|---|
| 3.1   | Avoiding sharp edges etc.                     | 5.4 and Annex B   |
| 3.2   | Making inherently safe                        | 6.3   |
| 3.3   | Taking into account design etc.               | 5 and 6   |
| 3.5   | Interaction of components                     | 5.3 and 6.2   |
| 3.10/3.12                                   | Limiting exposure to hazards etc.             | Annex B   |
| 5   | Information for use                           | Annex B   |



## Annex B (normative)

### Specification for information for use and maintenance of web lashing to be provided by the manufacturer

**B.1** In selecting and using web lashings, consideration shall be given to the required lashing capacity, taking into account the mode of use and the nature of the load to be secured. The size, shape and weight of the load, together with the intended method of use, transport environment and the nature of the load will affect the correct selection. For stability reasons free-standing units of load have to be secured with a minimum of one pair of web lashings for frictional lashing and two pairs of web lashing for diagonal lashing.

**B.2** The selected web lashings shall both be strong enough and of the correct length for the mode of use. Basic lashing rules:

- Plan the fitting and removal operations of lashing before starting a journey;
- Keep in mind that during journeys parts of the load may have to be unloaded;
- Calculate the number of web lashings according to prEN 12195-1:1995;
- Only those web lashings designed for frictional lashing with  $S_{TF}$  on the label are to be used for frictional lashing;
- Check the tension force periodically, especially shortly after starting the journey.

**B.3** Because of different behaviour and elongation under load conditions, different lashing equipment (e. g. lashing chain and web lashings) shall not be used to lash the same load. Consideration shall also be given to ancillary fittings (components) and lashing devices in the load restraint assembly are compatible with the web lashing.

**B.4** During use flat hooks (see D2 in Figure 1) shall engage over the complete width of the bearing surface of the hook.

**B.5** Release of the web lashing: Care should be taken to ensure that the stability of the load is independent of the lashing equipment and that the release of the web lashing shall not cause the load to fall off the vehicle, thus endangering the personnel. If necessary attach lifting equipment for further transport to the load before releasing the tensioning device in order to prevent accidental falling and/or tilting of the load. This applies as well when using tensioning devices which allow controlled removal.

**B.6** Before attempting to unload a unit of load its web lashings shall be released so that it can be lifted freely from the load platform.

**B.7** During loading and unloading attention has to be paid to proximity of any low overhead power lines.

**B.8** The materials from which web lashings are manufactured have a selective resistance to chemical attack.

Seek the advice of the manufacturer or supplier if exposure to chemicals is anticipated. It should be noted that the effects of chemicals may increase with rising temperature. The resistance of man-made fibres to chemicals is summarized below.

Polyamides are virtually immune to the effects of alkalis. However, they are attacked by mineral acids.

Polyester is resistant to mineral acids but is attacked by alkalis.

Polypropylene is little affected by acids and alkalis and is suitable for applications where high resistance to chemicals (other than certain organic solvents) is required.

Solutions of acids or alkalis which are harmless may become sufficiently concentrated by evaporation to cause damage. Take contaminated webbings out of service at once, thoroughly soak them in cold water, and dry naturally.

**B.9** Web lashings complying with this Part of EN 12195 are suitable for use in the following temperature ranges:

- 40 °C to + 80 °C for polypropylene (PP);
- 40 °C to + 100 °C for polyamide (PA);
- 40 °C to + 120 °C for polyester (PES).

These ranges may vary in a chemical environment. In that case the advice of the manufacturer or supplier shall be sought.

Changing the environmental temperature during transport may affect the forces in the web lashing. Check the tension force after entering warm areas.

**B.10** Web lashings shall be rejected or returned to the manufacturer for repair if they show any signs of damage.

The following criteria are considered to be signs of damage:

- Only web lashings bearing identification labels shall be repaired;
- If there is any accidental contact with chemical products, a web lashing shall be removed from service and the manufacturer or supplier shall be consulted;
- for web lashings (to be rejected): tears, cuts, nicks and breaks in load bearing fibres and retaining stitches; deformations resulting from exposure to heat;
- for end fittings and tensioning devices: deformations, splits, pronounced signs of wear, signs of corrosion.

**B.11** Care should be taken that the web lashing is not damaged by the sharp edges of the load on which it is used.

A visual inspection before and after each use is recommended.

**B.12** Only legibly marked and labelled web lashings shall be used.

**B.13** Web lashings shall not be overloaded: Only the maximum hand force of 500 N (50 daN on the label; 1 daN = 1 kg) shall be applied. Mechanical aids such as levers, bars etc. as extensions are not to be used unless they are part of the tensioning device.

**B.14** Web lashings shall never be used when knotted.

**B.15** Damage to labels shall be prevented by keeping them away from sharp edges of the load and, if possible, from the load.

**B.16** The webbing shall be protected against friction, abrasion and damage from loads with sharp edges by using protective sleeves and/or corner protectors.



---

---

## BSI — British Standards Institution

BSI is the independent national body responsible for preparing British Standards. It presents the UK view on standards in Europe and at the international level. It is incorporated by Royal Charter.

### Revisions

British Standards are updated by amendment or revision. Users of British Standards should make sure that they possess the latest amendments or editions.

It is the constant aim of BSI to improve the quality of our products and services. We would be grateful if anyone finding an inaccuracy or ambiguity while using this British Standard would inform the Secretary of the technical committee responsible, the identity of which can be found on the inside front cover.  
Tel: +44 (0)20 8996 9000. Fax: +44 (0)20 8996 7400.

BSI offers members an individual updating service called PLUS which ensures that subscribers automatically receive the latest editions of standards.

### Buying standards

Orders for all BSI, international and foreign standards publications should be addressed to Customer Services. Tel: +44 (0)20 8996 9001.  
Fax: +44 (0)20 8996 7001. Email: [orders@bsi-global.com](mailto:orders@bsi-global.com). Standards are also available from the BSI website at <http://www.bsi-global.com>.

In response to orders for international standards, it is BSI policy to supply the BSI implementation of those that have been published as British Standards, unless otherwise requested.

### Information on standards

BSI provides a wide range of information on national, European and international standards through its Library and its Technical Help to Exporters Service. Various BSI electronic information services are also available which give details on all its products and services. Contact the Information Centre.  
Tel: +44 (0)20 8996 7111. Fax: +44 (0)20 8996 7048. Email: [info@bsi-global.com](mailto:info@bsi-global.com).

Subscribing members of BSI are kept up to date with standards developments and receive substantial discounts on the purchase price of standards. For details of these and other benefits contact Membership Administration.  
Tel: +44 (0)20 8996 7002. Fax: +44 (0)20 8996 7001.  
Email: [membership@bsi-global.com](mailto:membership@bsi-global.com).

Information regarding online access to British Standards via British Standards Online can be found at <http://www.bsi-global.com/bsonline>.

Further information about BSI is available on the BSI website at <http://www.bsi-global.com>.

### Copyright

Copyright subsists in all BSI publications. BSI also holds the copyright, in the UK, of the publications of the international standardization bodies. Except as permitted under the Copyright, Designs and Patents Act 1988 no extract may be reproduced, stored in a retrieval system or transmitted in any form or by any means – electronic, photocopying, recording or otherwise – without prior written permission from BSI.

This does not preclude the free use, in the course of implementing the standard, of necessary details such as symbols, and size, type or grade designations. If these details are to be used for any other purpose than implementation then the prior written permission of BSI must be obtained.

Details and advice can be obtained from the Copyright & Licensing Manager.  
Tel: +44 (0)20 8996 7070. Fax: +44 (0)20 8996 7553.  
Email: [copyright@bsi-global.com](mailto:copyright@bsi-global.com).